



Kinetics LV (low voltage 0,07kW-375kW)

Electric motors for standard and heavy duty operations-powerfull, efficient and flexible

Technical datasheet



SOLUTIONS FOR INDUSTRY



SOLUTIONS FOR INDUSTRY

Datasheet for three-phase motors

Motor type: 1LC225M-6, 30 kW

Electrical data

| | |
|---|-------------|
| Power 50Hz (kW) | 30,00 |
| Power 60Hz (kW) | 36,00 |
| Frequency (Hz) | 50/60 |
| Voltage 50Hz (V) | 400/690 |
| Voltage 60Hz (V) | 460/795 |
| Voltage / frequency tolerance (invalid at range voltage) | Range B |
| Type of winding | Δ/Y |
| Number of poles | 6 |
| Efficiency 100% 50Hz (%) | 91,7 |
| Efficiency 75% 50Hz (%) | 92,1 |
| Efficiency 50% 50Hz (%) | 89,9 |
| Efficiency 100% 60Hz (%) | 93,0 |
| Efficiency 75% 60Hz (%) | 92,1 |
| Efficiency 50% 60Hz (%) | 89,9 |
| Power factor | 0,84 |
| Starting current (Ia/In) | 7,1 |
| Starting torque (Ma/Mn) | 2 |
| Breakdown torque (Mk/Mn) | 2,1 |
| Rated current 50Hz (A) | 56,21/32,59 |

General data

| | |
|------------------------|---------------------|
| Number of phases | 3- |
| Type designation | 1LC |
| Frame size | 225 |
| Type | B3 |
| Housing material | GG |
| Housing design | M |
| Insulation class | F/B |
| Terminal box position | top |
| Terminal box Alignment | 0 ° KV to the right |
| Weight (kg) | 285,00 |
| Direction of rotation | right/left |
| Vibration stage | A |
| Balancing | half key |
| Cooling type | IC411 |
| Version according to | IEC 60034-1 |
| Noise limit | IEC 60034-9 |

Mechanical data

| | |
|---------------------------------------|---------------|
| Torque (Nm) | 292,35/292,35 |
| Speed (rpm) | 980/1176 |
| Bearing (DE side) | 6313.ZZ.C3 |
| Bearing (NDE side) | 6313.ZZ.C3 |
| Bearing life (h) | 20000 |
| Permissible radial load (X/2) (N) | 6062 |
| Permissible radial load (X0) (N) | 6775 |
| Permissible radial load (Xmax) (N) | 5350 |
| Permissible axial load (N) | 5775 |
| Permissible axial load (V1) (N) | 4880 |
| Moment of inertia (kgm ²) | 0,534 |

Factors

| | |
|--------------------------|----------------------|
| Operation mode | duty interval S1 |
| Ambient temperature (°C) | -20 to +40 |
| Installation height (m) | altitude up to 1000m |

Motor characteristics

| | |
|-----------------------------|-------------|
| Painting | RAL7030 |
| Paint surface | satin gloss |
| Protection class | IP55 |
| Cable gland size (Cable) | 2xM50x1,5 |
| Cable gland size (option) | M20x1,5 |
| Cable gland (type) | standard |
| Standard shaft end (mm) | 60x140 |
| Shaft material | C45 |

Additional option

| | |
|------------------|-----------|
| Extra protection | PTC 150°C |
|------------------|-----------|

Low Voltage induction motors electric motors

HIGH EFFICIENCY

RELIABLE OPERATION

2 LOAD CLASSES

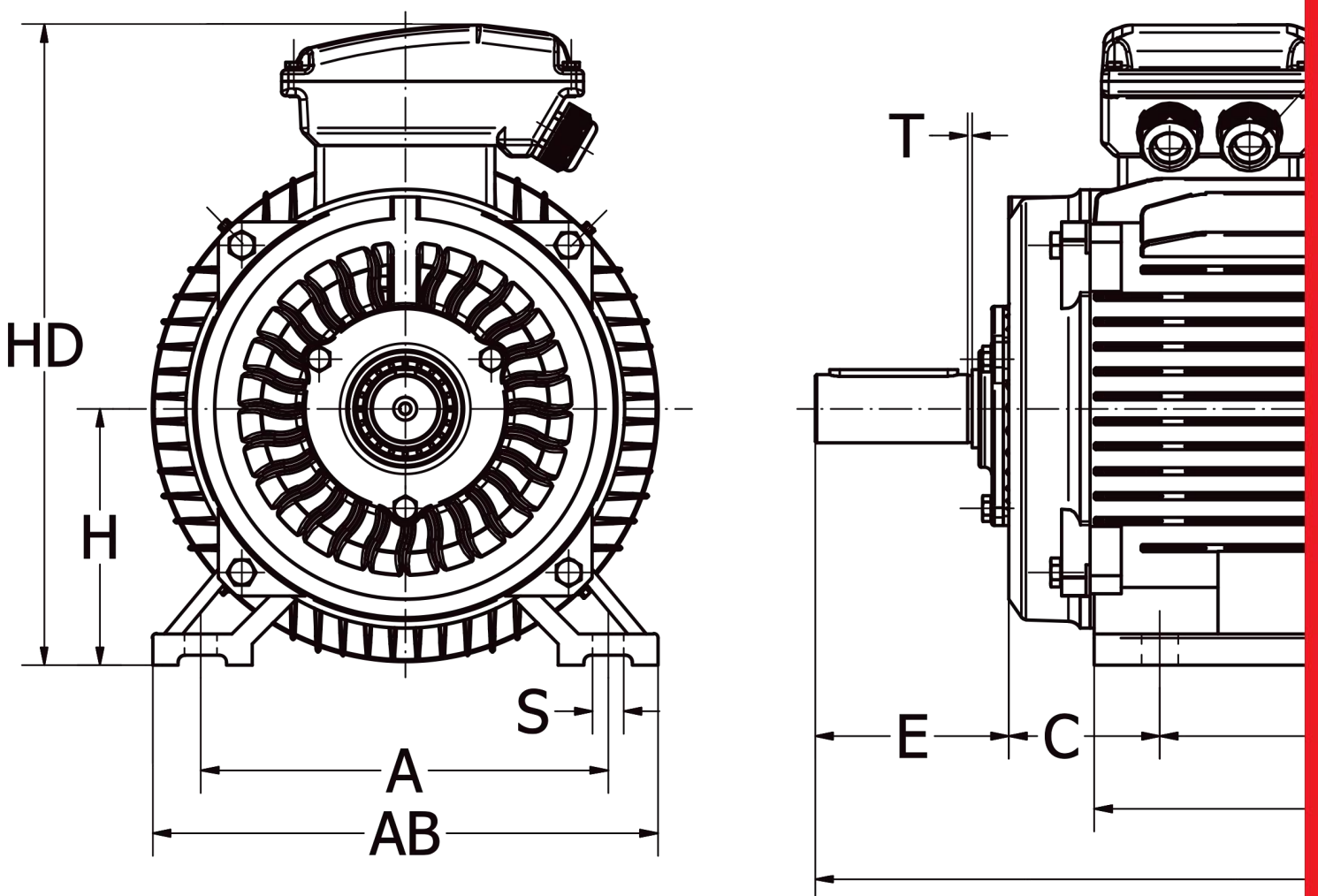

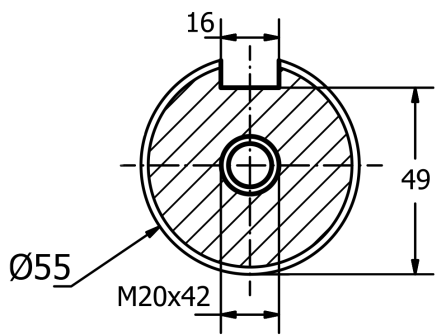
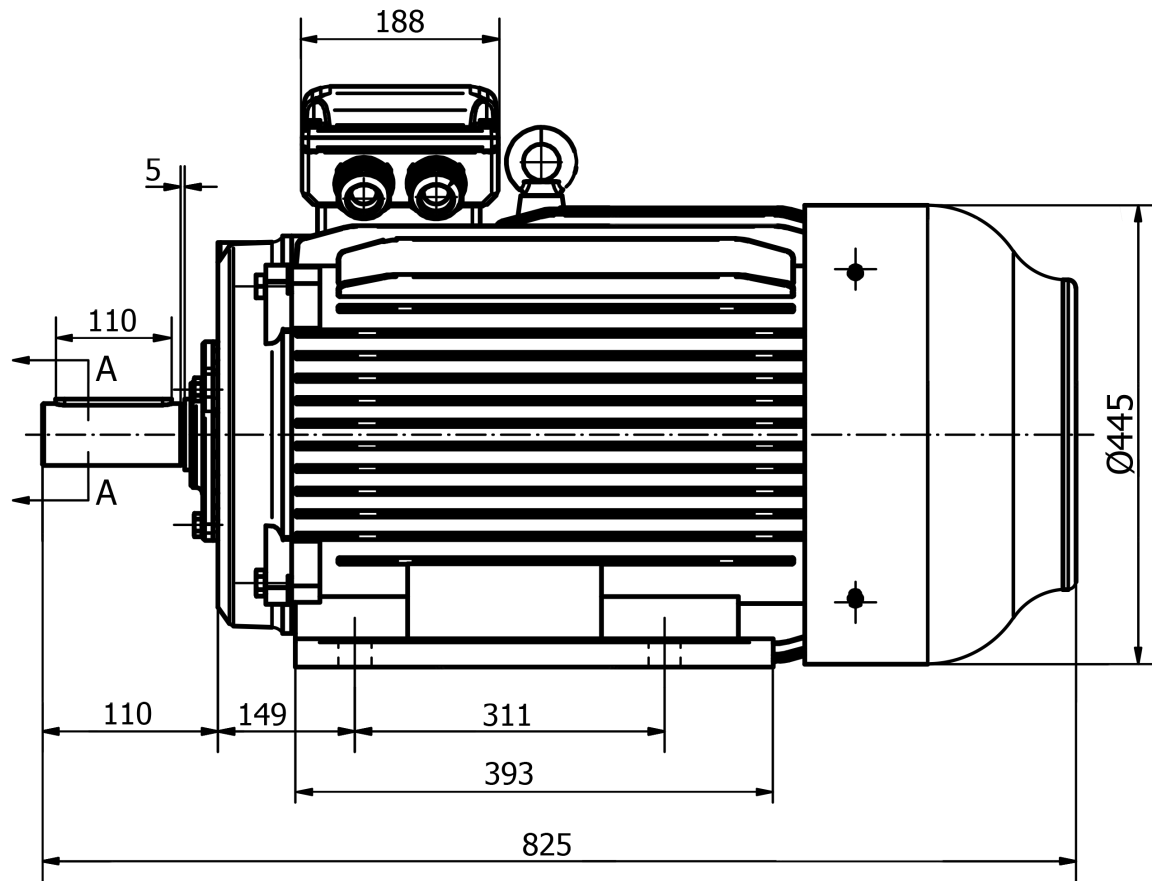
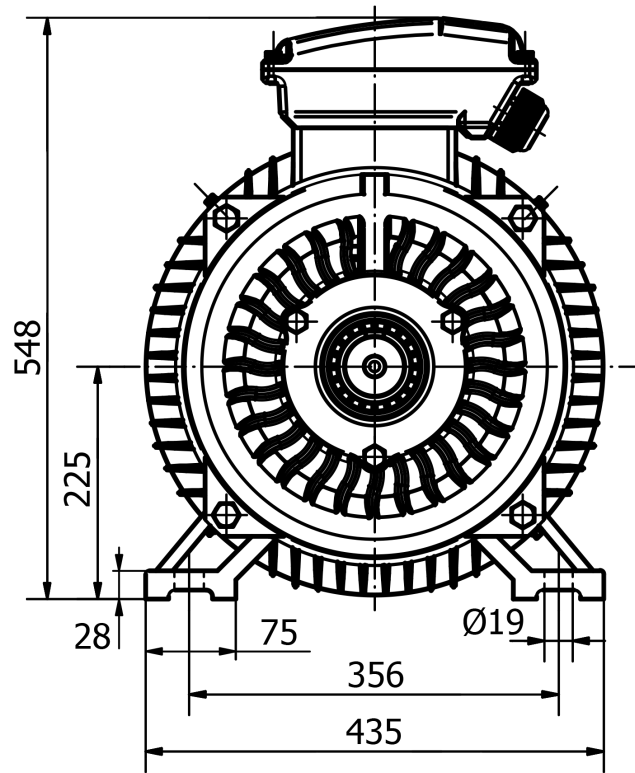

1 LC-225M-B3

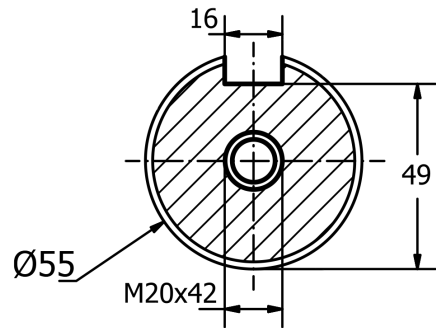
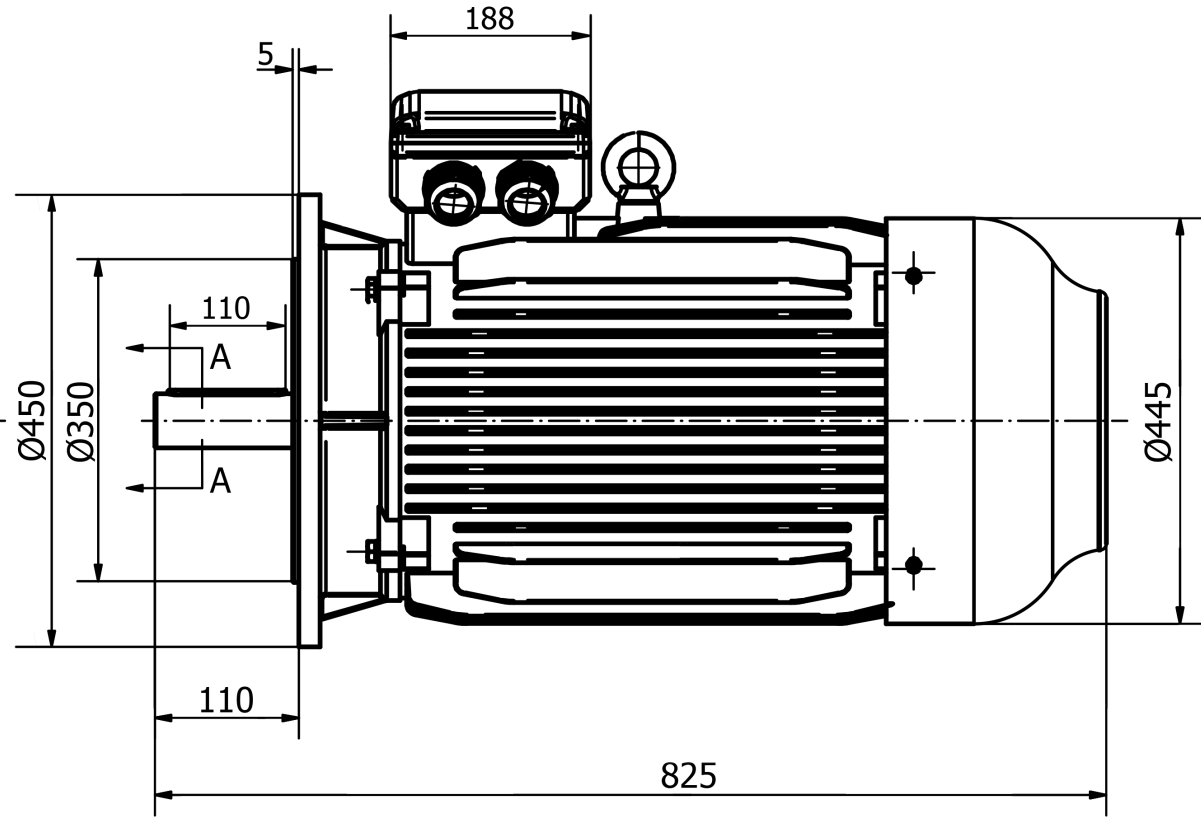
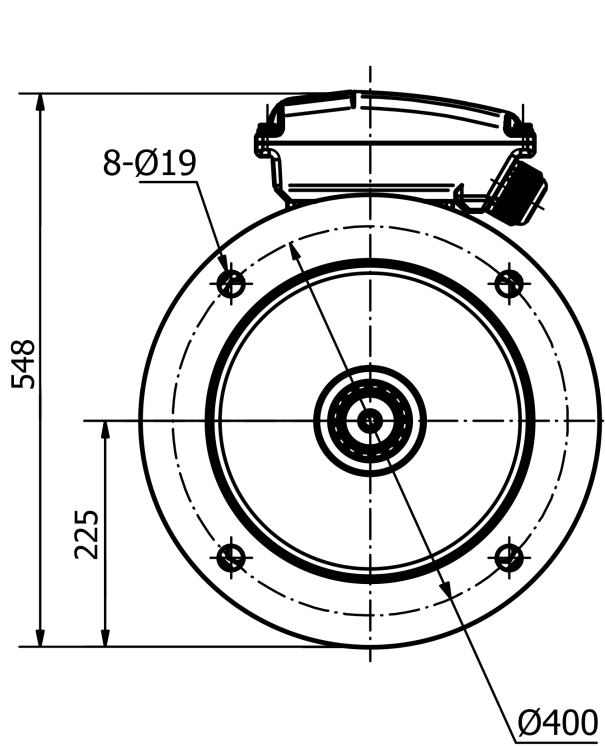

1 LC-225M-B5

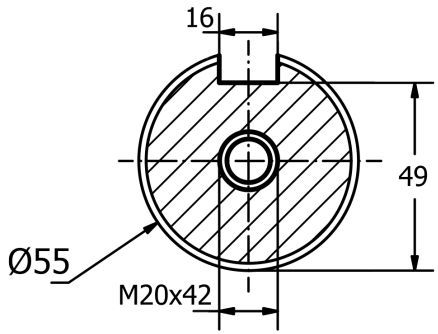
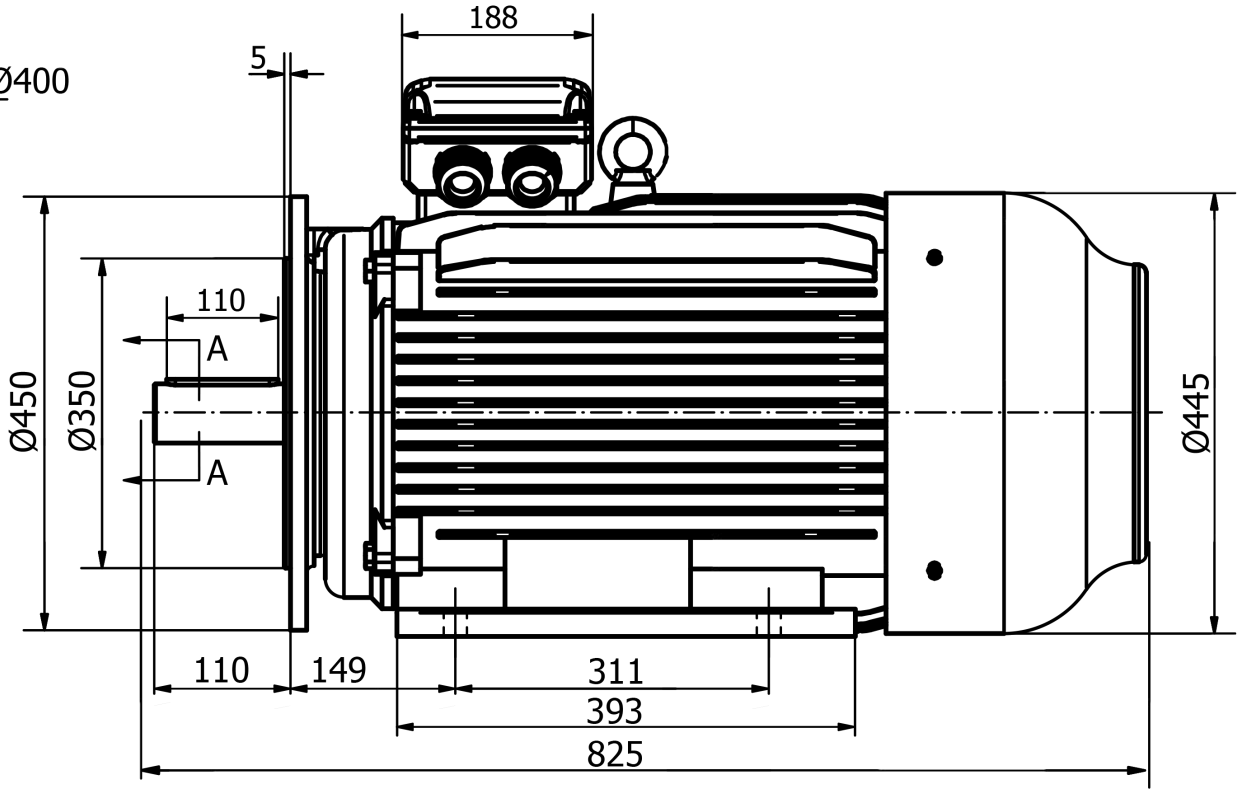
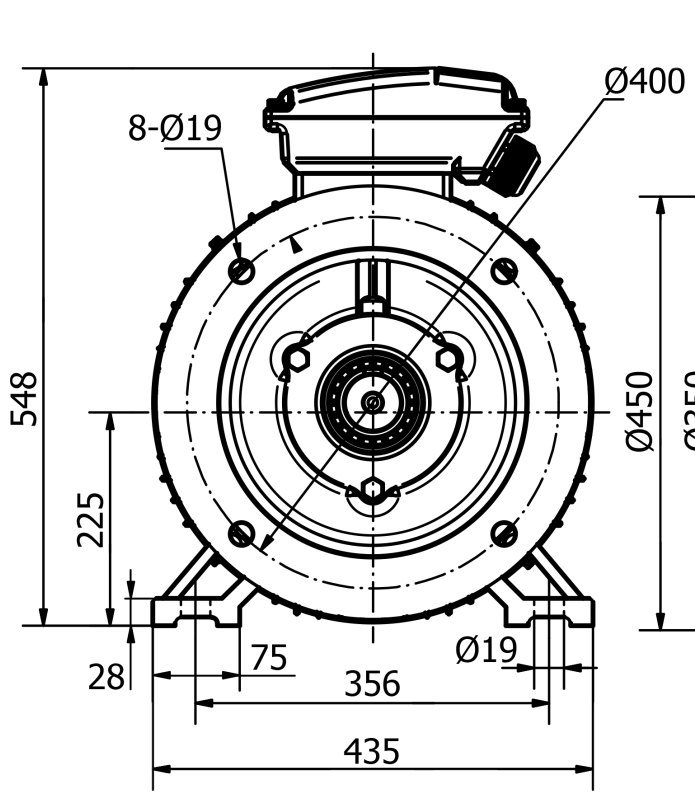

Vybo
 Electric

1 LC-225M-B35



- | HIGH EFFICIENCY
- | RELIABLE OPERATION
- | 2 CLASSES OF LOADS

